



SPELL JIF 6th Annual Mold, Environmental & IAQ Best Practices Seminar

**HVAC, Environmental Factors
&
Critical Measurements**

The Evolution of Commercial HVAC Systems

First there was just “H”



First there was just "H"



*More than
85,000
Nesbitt Unit Ventilators*

are rendering satisfactory service in every State of the Union
and in the Dominion of Canada

Finally, the claims for a unit ventilator are tested by daily performance.

The very first Nesbitt units—installed in the
Park Avenue School, Pleasantville, N. J., in 1917—
are still in operation and giving satisfactory service.

Since then more than 85,000 successful installations
have earned for Nesbitt the hearty approval of
school officials, architects and engineers.

Nesbitt Sales and Service are nation-wide
through offices of John J. Nesbitt, Inc.,
and American Blower Corporation . . . and
in Canada through Canadian Sirocco Company, Ltd.

Guarantee

NESBITT SYNCRETIZERS are manufactured by John J. Nesbitt, Inc., and are guaranteed to be free from defects in manufacture and operation. Nesbits will, after a year's use, accept the return and refund the full purchase price of any NESBITT SYNCRETIZER that has failed to perform as represented.

Publication 261—Section A, Printed in U. S. A. 1-50-17-5M

JOHN J. NESBITT, INC., MANUFACTURERS, PHILADELPHIA 36, PA., U. S. A.

First there was just “H”



First there was just “H”



If you wanted “V”



If you wanted “V”



Then came A/C



Then came A/C



Equipment Management



Equipment Management

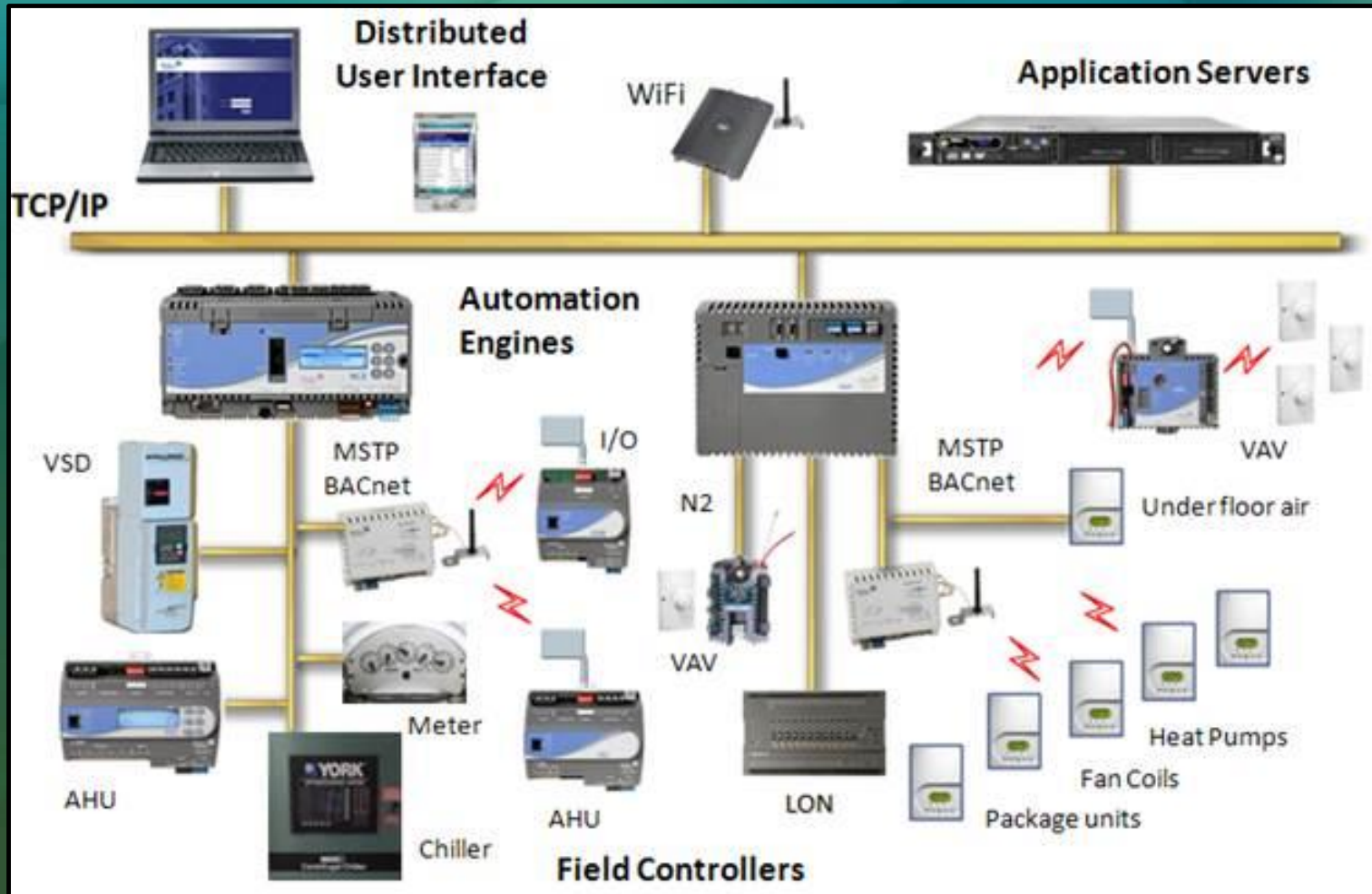

Then

- ✓ Low pressure steam
- ✓ Hot water
- ✓ Radiators
- ✓ Unit ventilators
- ✓ Exhaust fans
- ✓ Steam traps
- ✓ Manual control
- ✓ Pneumatic control

Now

- ✓ VAV's
- ✓ VRF's
- ✓ WSHP's
- ✓ GWSHP's
- ✓ OAU's
- ✓ AHU's
- ✓ CUV's
- ✓ HRU's
- ✓ FC's
- ✓ VFD's
- ✓ Split systems
- ✓ DX units
- ✓ Direct ventilation
- ✓ Blended ventilation
- ✓ Dehumidification
- ✓ Circuit setters
- ✓ Valve actuators
- ✓ Condensate pumps
- ✓ Chillers
- ✓ Cooling towers
- ✓ Ice storage
- ✓ LON
- ✓ BacNet
- ✓ ATC
- ✓ BAS
- ✓ TCP/IP (network attached)
- ✓ Web native

All this on order to...

Introduce Heat

Reject Heat

Add Clean, Fresh
and Dry Air

Change Factors That Contribute to Mold Growth

- ✓ Positive ventilation
- ✓ Air conditioning
- ✓ Energy efficiency
- ✓ Emission controls
- ✓ IEP's

Troubleshooting Approach

Linear

Systematic

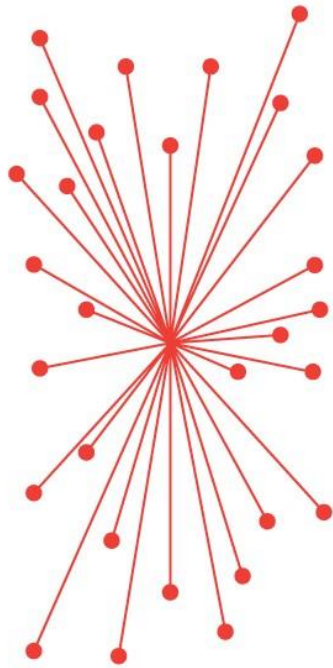

Linear thinking

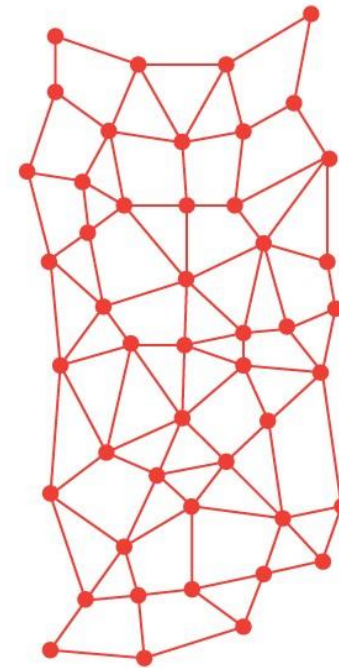

Non-linear thinking

New Construction/Renovation Considerations

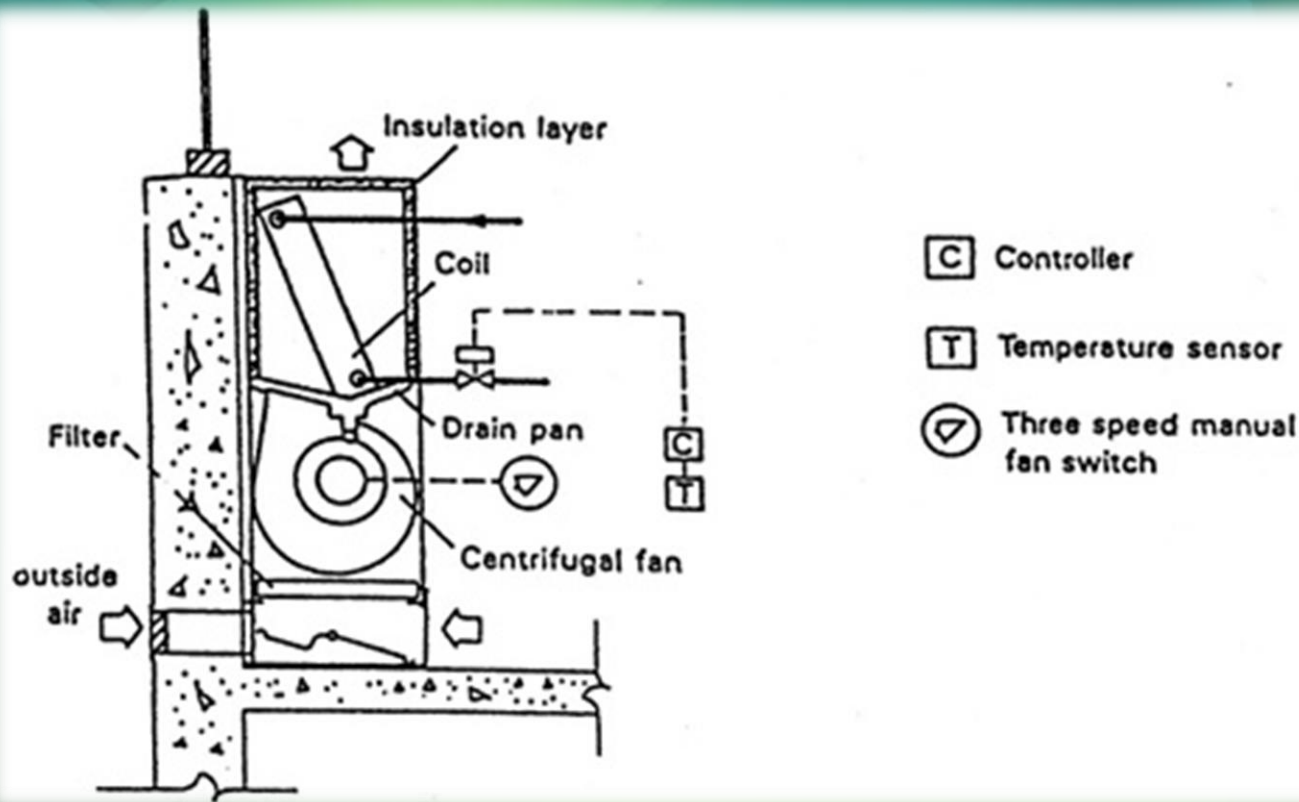

New Construction/Renovation Considerations

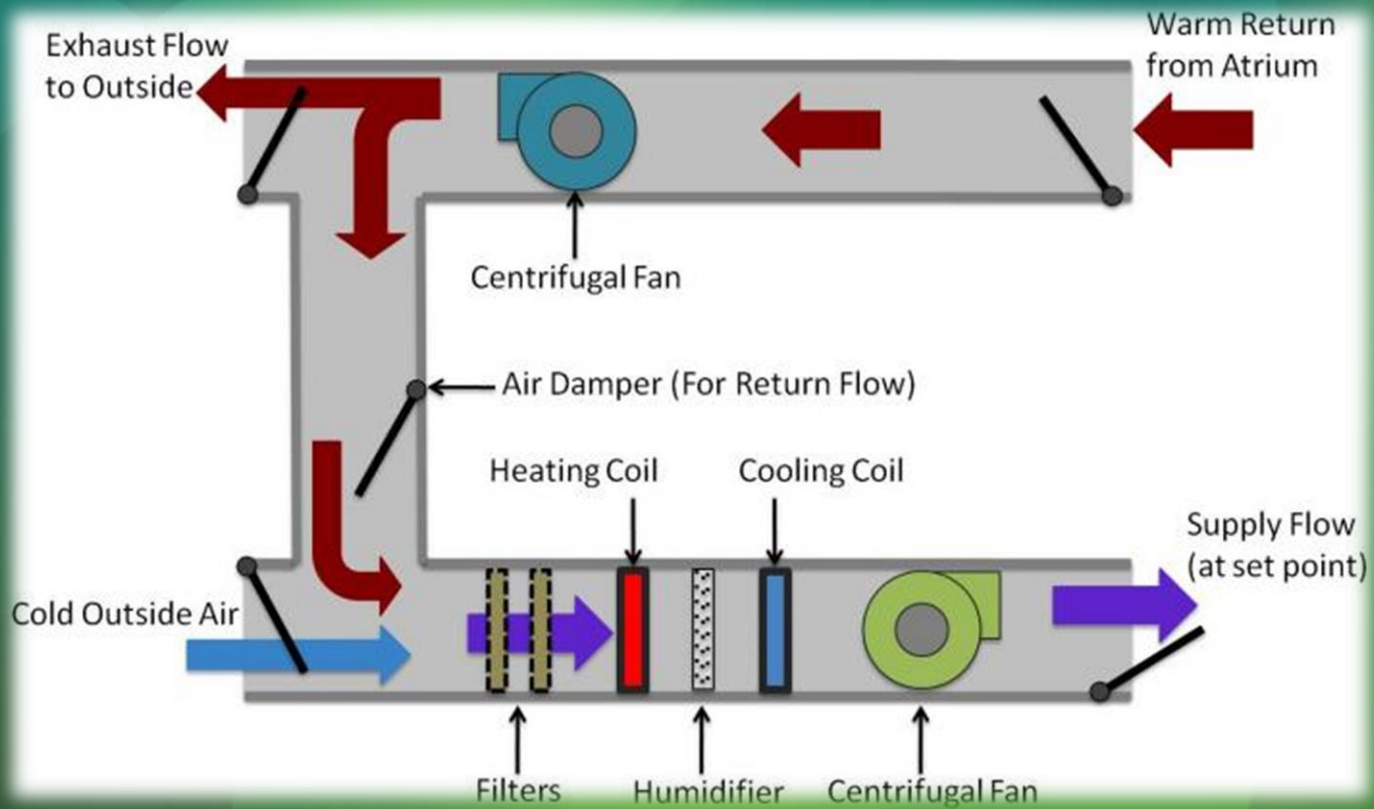

New Construction/Renovation Considerations



New Construction/Renovation Considerations



Case Study

- ❖ Issue began from an IAQ complaint
- ❖ Excessive humidity levels

Case Study

- ❖ Multi-story facility built in 1932
- ❖ Steam boiler/hot water
- ❖ Some split VRF systems
- ❖ Recent HVAC renovation
- ❖ Chilled water
- ❖ UV's with economizer and dehumidification
- ❖ Wireless control systems

Case Study



Case Study



Case Study



Case Study



Case Study

- ❖ No boiler controls
- ❖ Elevated steam pressure
- ❖ 260 gallons of water steamed off per day!
- ❖ Pressurized crawl space
- ❖ Numerous floor penetrations
- ❖ Numerous communication failures in new wireless ATC system
- ❖ No high condensate sensors in AHU's

Case Study - Outcome

- ❖ Re-establish boiler controls
- ❖ Return steam pressure to normal levels
- ❖ Boiler make-up water at 70 gallons per day
- ❖ Ventilate crawl space
- ❖ Seal floor penetrations
- ❖ Still working to correct communication failures in new wireless ATC system
- ❖ Service classroom UV
- ❖ Classroom RH levels returned to normal
- ❖ Install and program condensate sensors in AHU's

Clean Electrical Power and Network Consideration for Optimum Controls Performance

- ❖ Legacy transforms, outdated wiring, properly sized neutrals
- ❖ Flat networks

Knowledge and diligence will avoid this...



FOX29.COM

FOX 29

7:32 57°

MOLD OUTBREAK WORRIES PARENTS
AFTER MORE SCHOOLS CLOSE

#FOX29 VALLEY (#74) - CONSTRUCTION - STARTING ON FRIDAY OCT. 13 A. 69°



Mold And Mushrooms Found In DPS Schools



SOUTH JERSEY

4:05 81°

NBC 10

NBC10 PHILADELPHIA

Thank You!

Questions...

?